

Instruction Manual for the

Estate **SLIDE**

E-SL 1200 / E-S 1202 Series



Featuring:

One Touch
EZ Programming

WARNING!

Read all instructions before beginning installation or use of this gate opener. This operator exerts a high level of force. Exercise caution at all times and stay clear of the system during operation.

Manufactured by

FAAC
An ISO 9001 Certified Company

CE DECLARATION OF CONFORMITY OF MACHINES

(Directive 89/392/EEC, Annex II, Part B)

Manufacturer: FAAC S.p.A.

Address: Via Benini, 1 – 40069 Zola Predosa Bologna – Italy

Declares that: 740 A.K.A. Estate Slide 1800 (USA) mod operator

- Is built to be integrated into a machine or to be assembled with other machinery to create a machine under the provisions of Directive 89/392/EEC, and subsequent amendments 91/368/EEC, 93/44/EEC.
- Conforms to the essential safety requirements of the following EEC directives:
 - o 73/23/EEC and subsequent amendment 93/68/EEC, 89/336/EEC and subsequent amendment 92/31/EEC and 93/68/EEC.
 - o And also declares the it is prohibited to put into service the machinery until the machine in which it will be integrated or of which it will become a component has been identified and declared as conforming to the conditions of Directive 89/392/EEC and subsequent amendments assimilated under national laws under DPR #459 of July 24, 1996.

Bologna, January 1, 2002

Managing Director

A. Bassi



**Warnings for the Installer
General Safety Obligations**

1. Attention! To ensure the safety of people, it is important that you read all the following instructions. Incorrect installation or incorrect use of the product could cause serious harm to people.
2. Carefully read the instructions before beginning to install the product.
3. Store these instructions for future reference.
4. This product was designed and built strictly for the use indicated in the documentation. Any other use, not expressly indicated here, could compromise the good condition/operation of the product and/or be a source of danger.
5. FAAC declines all liability caused by improper use or use other than that for which automated system was intended.
6. Do not install the equipment in an explosive atmosphere; the presence of inflammable gas or fumes is a serious danger to safety.
7. The mechanical parts must conform to the provisions of Standards EN 12604 and EN 12605.

For non-EU countries, to obtain an adequate level of safety, the standards mentioned above must be observed, in addition to national legal regulations.

8. FAAC is not responsible for failure to observe Good Technique in the construction of the closing elements to be motorized, or for any deformation that may occur during use.
9. The installation must conform to Standards EN 12453 and EN 12445.

The safety level of the automated system must be C+D.

10. Before attempting any job on the system, cut out electrical power and disconnect the batteries.
11. The main power supply of the automated system must be fitted with an all-pole switch with contact opening distance of 3 mm or greater. Use of a 6A thermal breaker will all-pole circuit break is recommended.
12. Make sure that a differential switch with threshold of 0.03 A is fitted upstream of the system.
13. Make sure that the earthing system is perfectly constructed, and connect metal parts of the means of the closure to it.
14. The automated system is supplied with an intrinsic anti-crushing safety device consisting of a torque control. Nevertheless, its tripping threshold must be checked as specified in the Standards indicated at point 10.
15. The safety devices (EN 12978 standard) protect any danger areas against mechanical movement risks, such as crushing, dragging, and shearing.
16. Use of at least one indicator-light (e.g. FAACLIGHT 12VDC) is recommended for every system, as well as a warning sign adequately secured to the frame structure, in addition to the devices mentioned at point "15".
17. FAAC declines all liability as concerns safety and efficient operation of the automated system, is system components not produced by FAAC are used.
18. For maintenance, strictly use original parts by FAAC.
19. Do not in any way modify the components of the automated system.
20. The installer shall supply all information concerning manual operation of the system in case of an emergency, and shall hand over to the user the warnings hand-book supplied with the product.
21. Do not allow children or adults to stay near the product while it is operating.
22. Keep remote controls or other pulse generators away from children, to prevent the automated system from being activated involuntarily.
23. Transit through the leaves is allowed only when the gate is fully open.
24. The user must not attempt any kind of repair or direct action whatever and contact qualified personnel only.
25. Do not short-circuit the poles of the batteries and do not try to recharge the batteries with power supply units other than Master or Slave cards.
26. Do not throw exhausted batteries into containers for other waste but dispose them in the appropriate containers to enable them to be recycled.
27. **Anything not expressly specified in these instructions is not permitted.**

Estate Slide Summary of Functions

The Estate Slide is only to be used for vehicular Slide Gates in a Class I setting.

Class I: A vehicular gate opener (or system) intended for use in a home of one-to-four single family dwelling, or a garage or parking area associated therewith.

The FAAC Estate Slide automated system was designed and built for controlling vehicle access. Do not use for any other purpose.

The Estate Slide automated system automates residential slide-leaf gates with leaves of up to 16' in length. It consists of a locking electro-mechanical linear operator, powered by a 12V DC battery, coupled with a control board recharging the battery. The MASTER card can be programmed and is used to set the following: function logics, work times (by self-learning) and pause times, leaf speed, and the sensitivity of the anti-crushing device.

The locking system will automatically lock when the motor is not operating. A release system enables the gate to be moved by hand in case of a system failure.

For Your Assistance





Keep this manual safely stored after installation.

Serial Number	
Date of Purchase	
Place of Purchase	

Have this information on hand while handling all service and warranty issues.

This manual and its contents are produced by Web Direct Brands, Inc. and is based on the instructions written by FAAC, International.

The table of contents is listed to assist you locating a desired section. We do however strongly suggest studying every page of the instruction manual before attempting installation.

	Page(s):	
Specifications of the Estate Slide and Components	1.1	
System Overview & Preliminary Checks	2.1	
Tools Needed for Installation	3.1	
IMPORTANT: Charging Battery Prior to Use	4.1	
Manual Operation	5.1	
Installation of Base, Operator and Limits	6.1 - .4	
Control Board Layout	7.1	
Power	8.1	
Control Board Pre-Learning Preparations	9.1	
One Touch EZ Programming	10.1	
Programing Gate Movement Variables (i.e. auto-close, speed, force, delays)	11.1	
Gate Movement Variables LED Chart	12.1	
Logic Summaries and Flow Charts	13.1-2	
Receiver Programming	13.3	
Accessory Terminals	14.1-2	
Simple Diagnostics	15.1	
Photocell & Safety Device Guide	16.1-2	
Warranty Notice	17	



Marks pages with opener or usage warnings. Although we have marked these as very important warnings, **please read the entire manual. Every step** is important to the correct installation of your gate opener.

MODEL	Estate Swing
Power Supply	115V AC/ 24V DC
Rated Absorbed Power (W)	48
Max Static Force (N)	560
Load-free linear speed (in./sec.)	10
Use frequency (cycles/hour)	5
Consecutive cycles on charged battery	Max. 15
Battery recharge time	10 min. for each full cycle
Operating ambient temperature	-4 to 131°F
Operator weight (lbs.)	4.85
Protection Class	IP 44
Gate leaf max length (ft.)	Up to 12
Gate leaf max weight (lbs.)	Up to 550
Operator overall dimensions LxHxD (in.)	See below
Length of operator power cable (ft.)	2.3

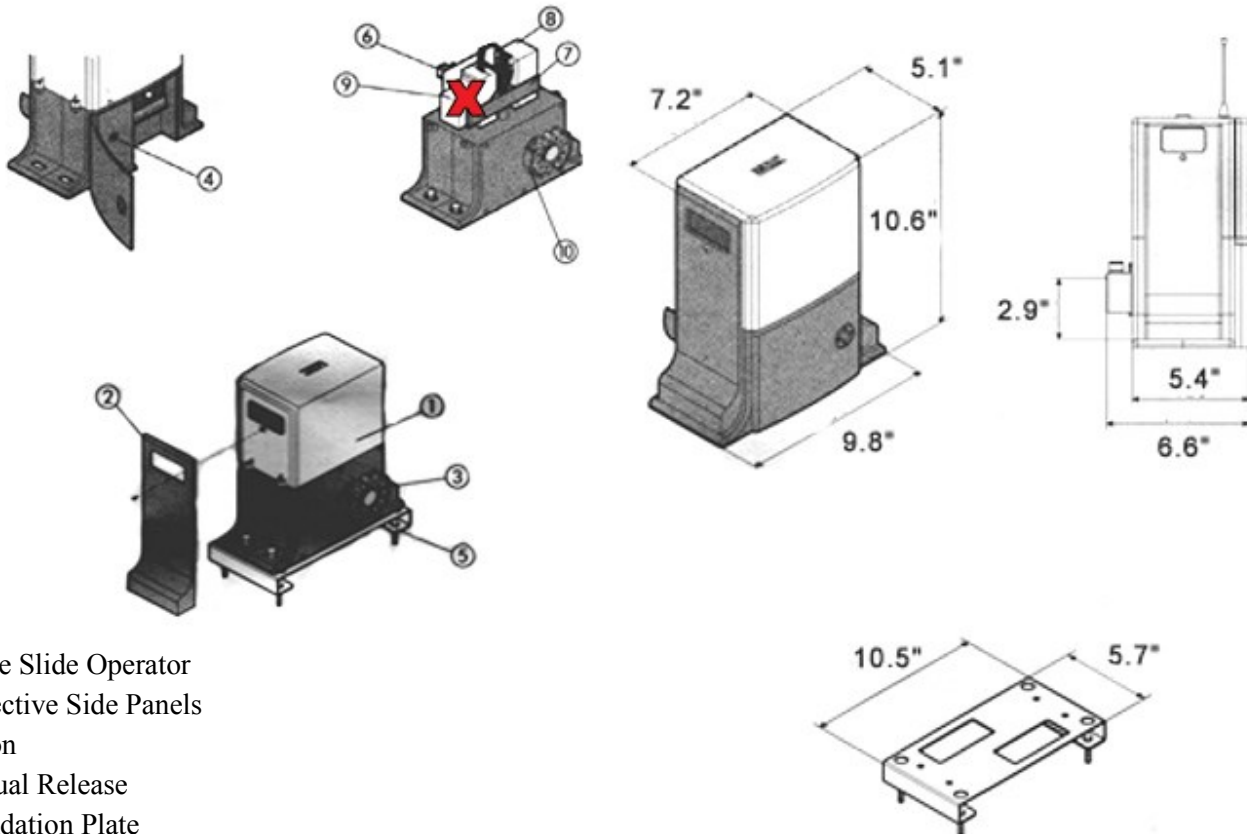

1. Estate Slide Operator
2. Protective Side Panels
3. Pinion
4. Manual Release
5. Foundation Plate
6. Control board
7. Battery and transformer support
8. Battery
9. Transformer (Remotely located)
10. Hand guards

Standard System Overview and Safety Zones

The system display to the right is a recommended standard system. Other approved accessories can be installed. Photo sensors and a flashing light indicating gate movement is recommended for safety purposes.

- 1 Estate Slide Operator
- 2 Photocells (not included)
- 3 Key operated pushbutton (not included)
- 4 Flashing lamp (not included)
- 5 433 Receiver



Notes:

- 1) Do not extend operator connection cables.
- 2) When laying electrical cables, use appropriate rigid and/or flexible tube.
- 3) Do not run any wires in the same conduit as 110 AC power that may be in the area. This will cause unwanted interference.

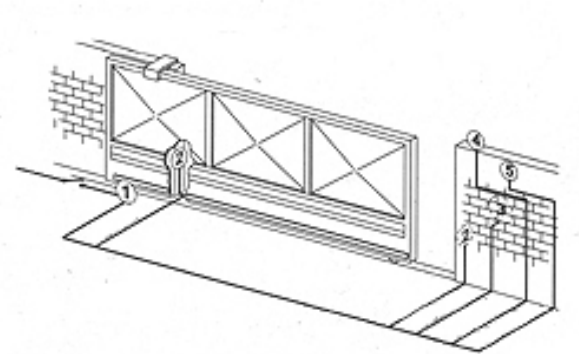

IMPORTANT Preliminary Checks:

To ensure safety and an efficiently operating automated system, make sure the following conditions are observed.

- The gate and post must be suitable for being automated. Check that the structure is sufficiently strong and rigid, and its dimensions and weights conform to those indicated in section 1. In particular, wheel diameter must be in relation to the weight of the gate to be automated. Dimensions and weight must match those indicated in the technical specifications.
- Make sure the leaves move smoothly without any irregular friction during entire travel.
- The soil must permit sufficient stability for the expansion plugs securing the foundation plate.
- Check if the upper guide and travel limit mechanical stops are installed.

We advise you to have any metalwork carried out before the automated system is installed.

Tools Needed



- Power Drill
- Crescent Wrench
- 3/8" Drill Bit
- Hacksaw
- Flat Head Screwdriver
- Phillips Head Screwdriver
- Tape Measure
- Level
- Wire Strippers
- C-clamps

Other items that may be needed prior to commencing installation.

- Additional low voltage wire may be required to run power to your operator. Length is determined by distance between transformer power supply and the control box.
- If the gate is more than 1000' from an a/c power supply then an alternate power will be necessary to charge your battery.
- Depending on the current base, you may need cement to form a level mounting pad.
- A voltage meter may be necessary to run diagnostic checks.
- A digital camera will come in handy with technicians if any support is needed.
- Protect all ingoing and outgoing wire with a surge suppressor. Consult your local dealer for more information.

IMPORTANT: Charging Battery Prior to Use

Before beginning any electrical stages of installation, we highly recommend charging the battery on the control board for **12 hours**. This can be done anywhere where an outlet is available.

1. Plug the battery into the control board (fig. 1). For charging purposes it is not necessary to hook the receiver to the battery or control board.
2. Insert the wires from the supplied AC transformer into the terminal J2 of the control board. **NEVER RUN 110V AC OR POWER THROUGH ANY OTHER METHOD BESIDES THE PROVIDED TRANSFORMER TO THE CONTROL BOARD.**
3. Let the unit charge for 12 hours, you can proceed with the installation process after battery is charged.

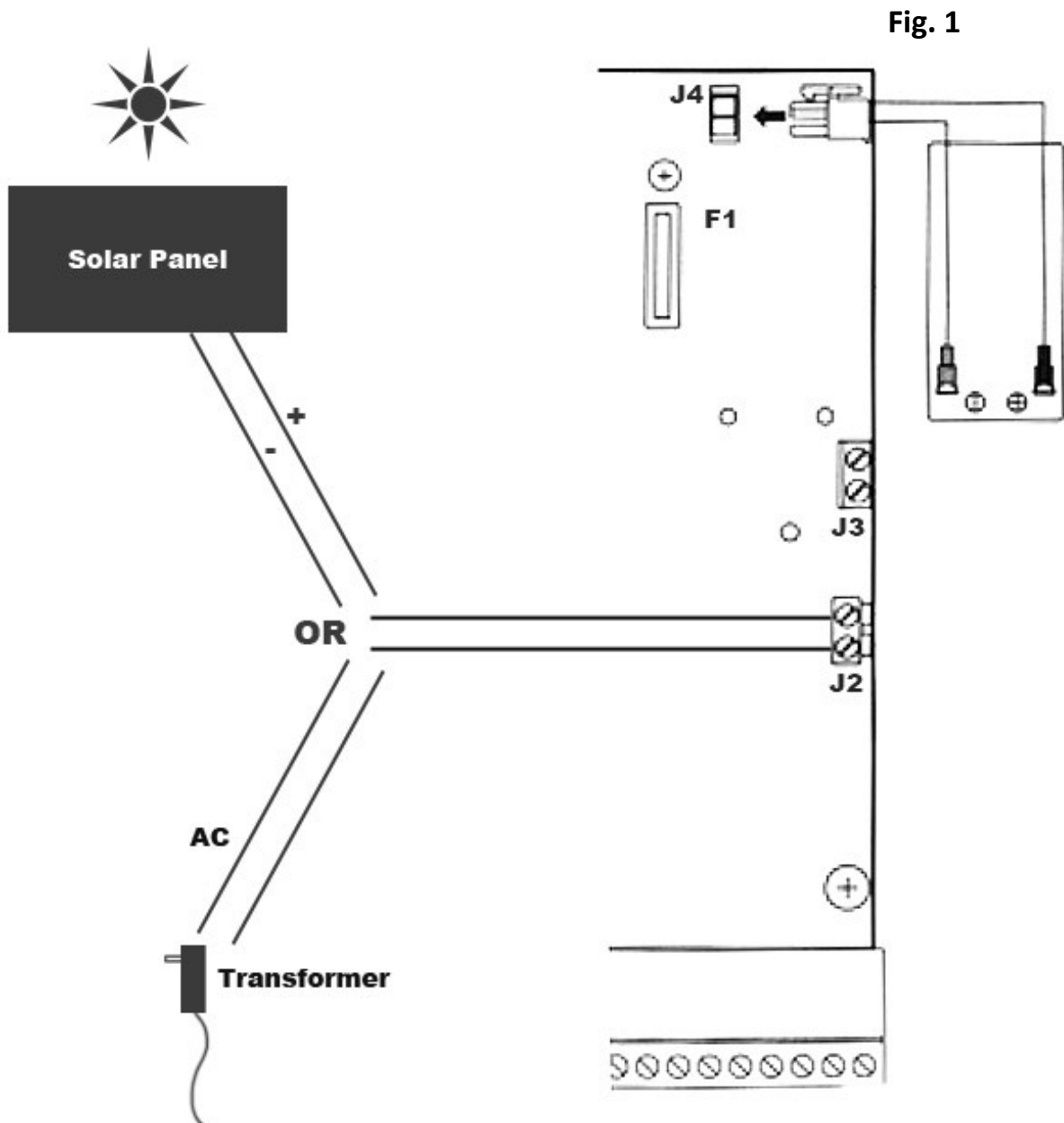

Manual Operation

1. Open the protective door by turning the slotted lock with a coin or large flat head screw driver.
2. Take the supplied key located inside the door, fit it in the release system and turn it clockwise until it reaches the mechanical stop.
3. Open or Close the gate manually.

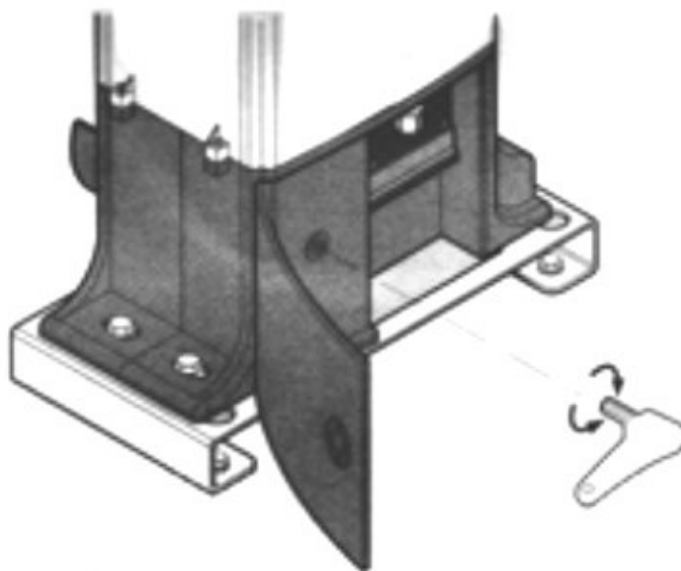

Installation of Mounting Hardware

Set the Foundation Plate

1. Fit the supplied caged nuts, as shown below, in the 4 square holes of the plate.

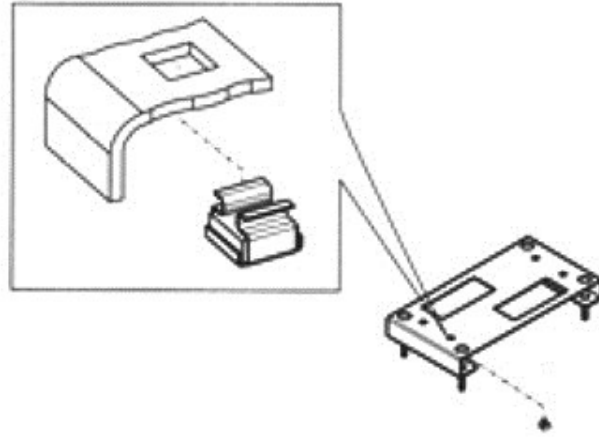

2. The foundation plate must be located as shown in example A (right closing) or example B (left closing) to ensure the rack and pinion mesh correctly.

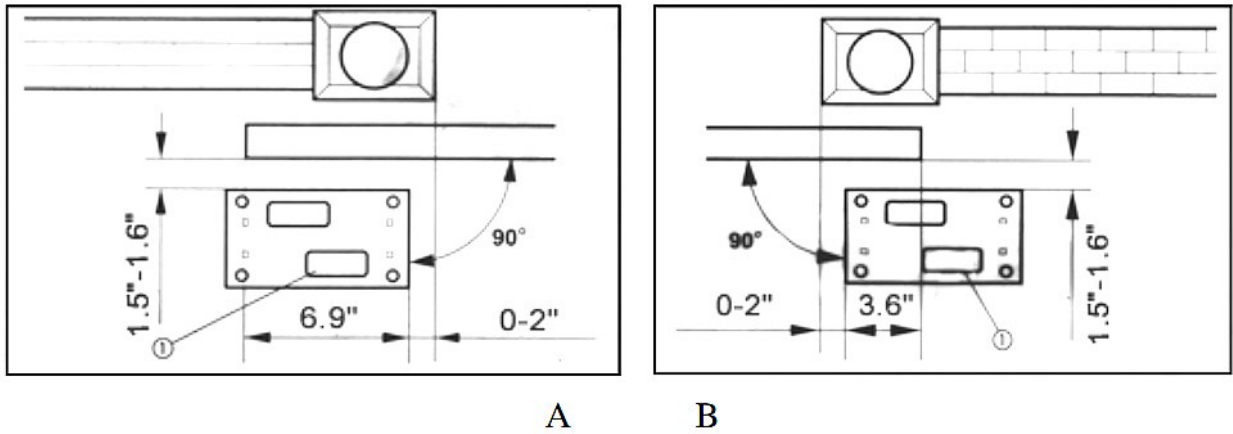

3. Secure the foundation plate to the floor, using adequate expansion plugs (below) and provide one ore more sheaths for routing the electrical cables. Using a level, check if the plate is perfectly level.

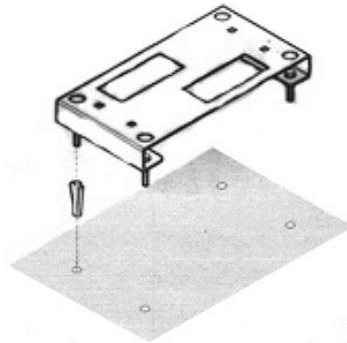

Installation of Mounting Hardware

4. Lay the electric cables for connection to the accessories and power supply. To facilitate making connections, allow the cables to project by about 8 inches from the hole of the foundation plate.

Operator Installation

1. Position the operator on the plate using the supplied screws as shown below.

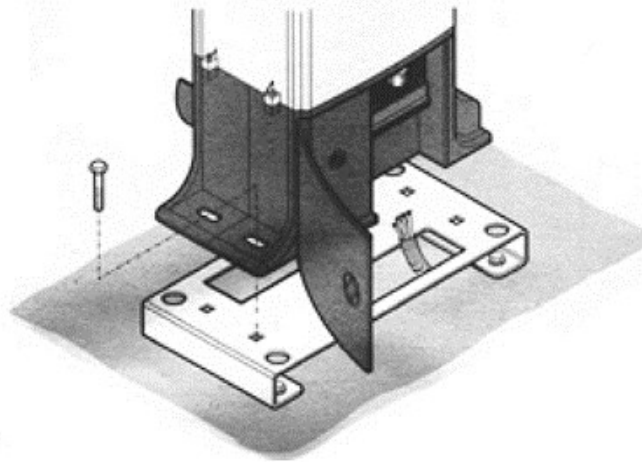

2. Secure the operator to the foundation plate, tightening the screws as shown below.

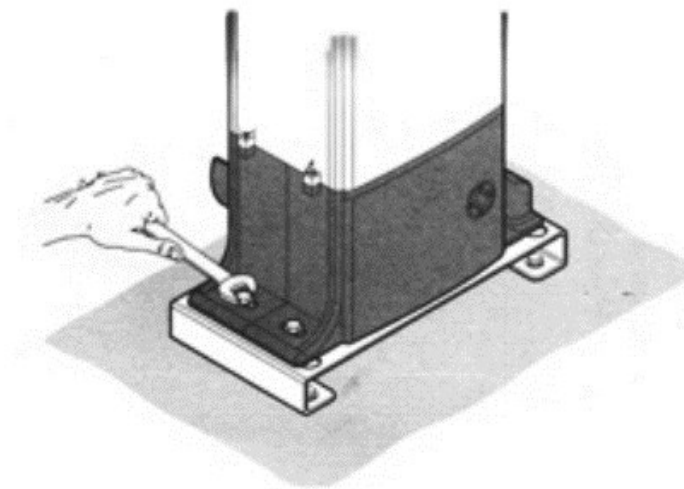

3. Prepare the operator for the manual operating mode as described in Section 5.

Rack Installation

1. Manually take the leaf to its close position.
2. Lay the first piece of rack at the appropriate level and mark the hole position on the gate. Make a hole and use nuts, bolts and washers to make a connection to the gate (not provided)

The holes in the rack are made oblong for adjustment after the holes are drilled. No special bolts are required for mounting, simply tightening the bolts will hold the rack secure.

3. Move the gate manually, checking if the rack is resting on the pinion. Repeat at each hole.
4. Bring another rack element neat the previous one, using a piece of rack (as shown below) to synchronize the teeth of the two elements.
5. Move the gate manually and carry out the securing operations as far as the first element, proceeding until the gate is fully covered.

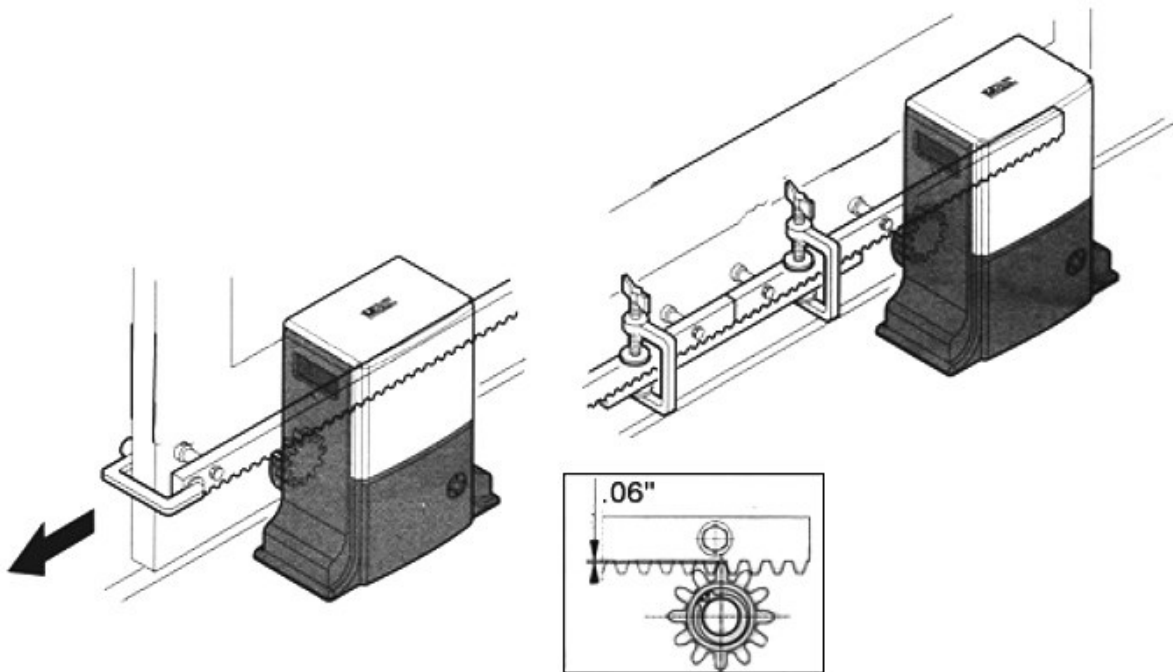

Notes on rack installation

- Make sure that during the gate travel, all the rack elements mesh correctly with the pinion.
- Do not, on any account, weld the rack elements either to the spacers or to each other.
- When you have finished installing the rack, adjust the distance between the pinion teeth and the rack groove. Check if the distance is .06" (below) along the entire travel using the rack slots.
- Manually check if the gate habitually reaches the travel limit mechanical stops and make sure that there is no friction during gate travel.
- Do not use grease or other lubricants between rack and pinion.

Travel Limit Magnet Installation

The Estate Slide operator is supplied with a sensor, by detecting the transit of two magnets secured to the top of the rack, it commands gate movement to stop.

1. Position the magnets on the rack as shown below.

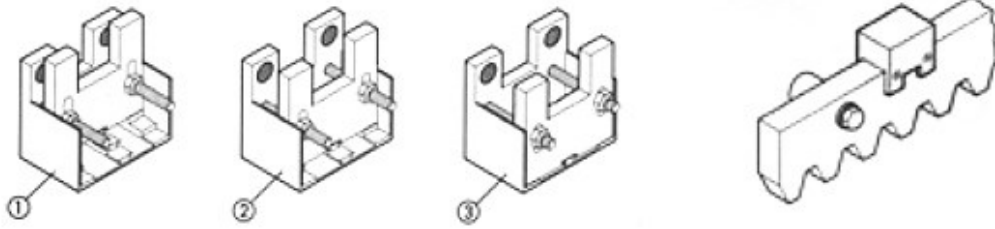

2. Power up the control board and enter the diagnostic mode (Chapter 10)

3. Manually take the gate to the open position, but allow a space of 2 cm from the travel limit mechanical stop position. Slide the magnet on the rack until you see that LED 1 on the control board goes off. Tighten the magnet's securing screws.
4. Manually take the gate to the closed position, but allow a space of 2 cm from the travel limit mechanical stop position. Slide the magnet on the rack until you see that LED 1 on the control board goes off. Tighten the magnet's securing screws.

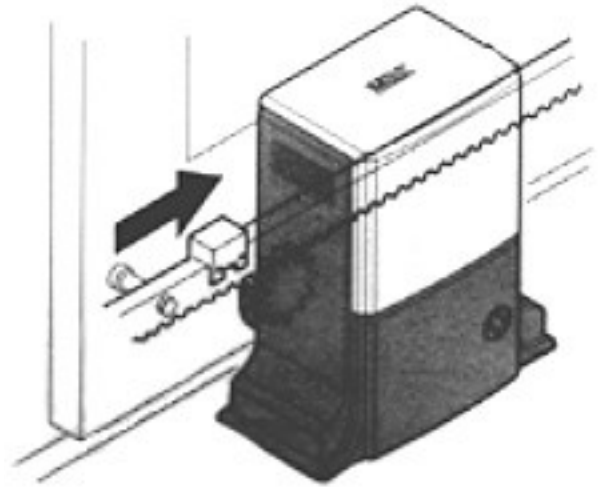

5. Re-lock the operator.

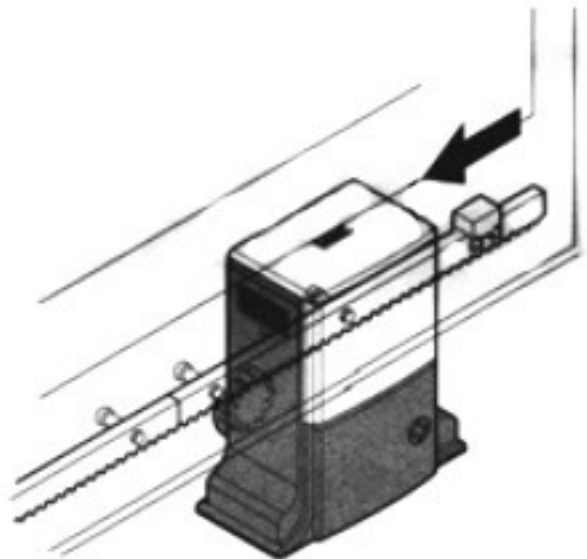

Control Board Layout

ATTENTION: Study the control board and read this section thoroughly before attempting to operate your gate opener.

Warnings:

Before attempting any job on the control board (connections, maintenance), turn off electrical power and unplug the support battery.

Install a surge protector upstream of your opener, the opener is not power surge proof not will power surge damage be covered under warranty.

Always separate power from control and safety cables (push-buttons, receivers, photocells, etc.). To avoid any electrical noise, use separate sheaths or a shielded cable (with earthed shield)

Layout of Control Board

DO NOT alter position from factory.

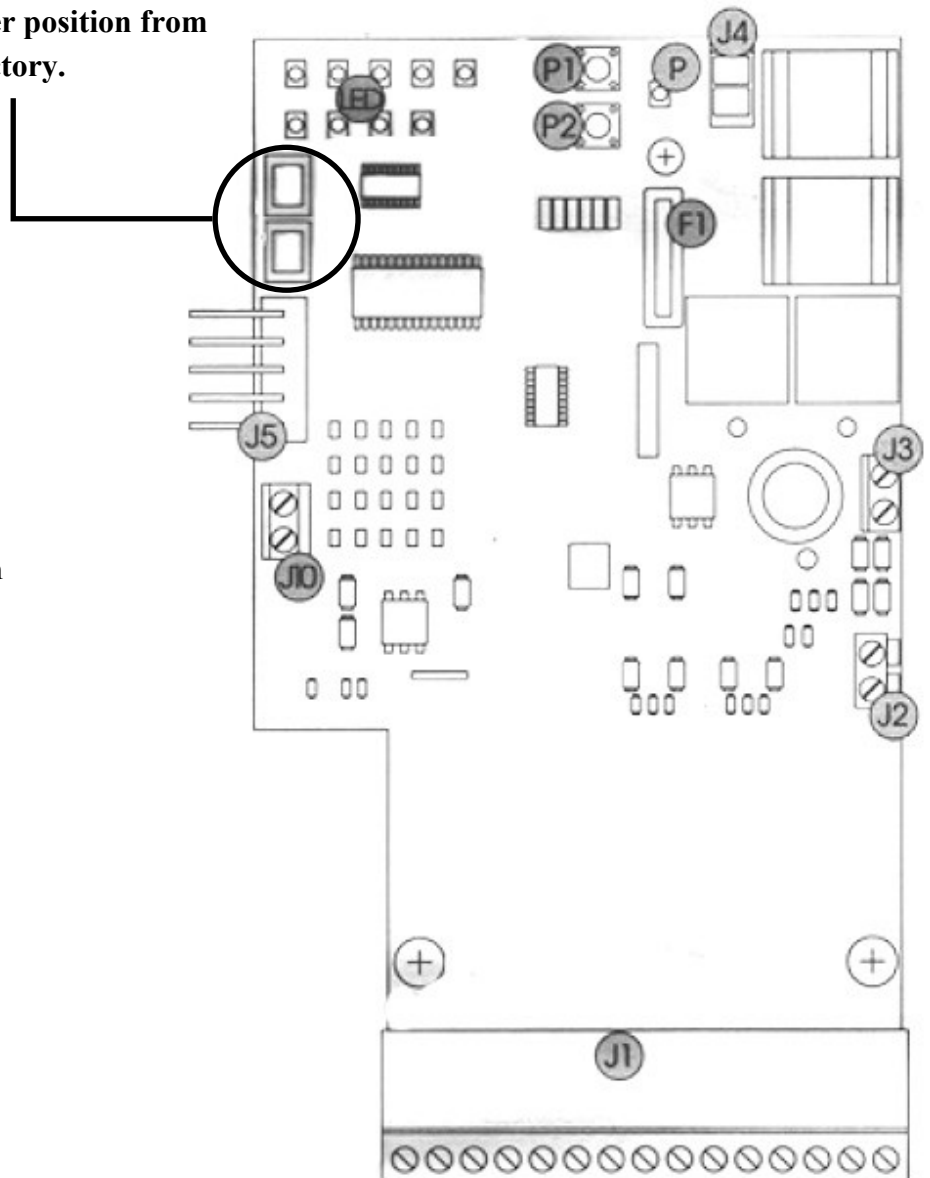

- LED** Programming LEDs
- P** Power ON and diagnostics LED
- P1** “Function” programming push-button
- P2** “Value” programming push-button
- F1** Battery and motor fuse - F15A
- J1** Accessories Terminal board
- J2** Transformer or Solar Terminal
- J3** Motor connection terminal
- J4** Battery connector
- J5** 433 receiver
- J10** Sensor Terminal Board

Power

1. The Estate Slide comes with 1) AC Transformer or a solar panel. You may locate the transformer up to **1000'** **away from the control board with 16 gauge or larger direct burial low voltage wire. Allow a minimum of 4' of wire between the control board and the transformer.**
2. Insert the two wires into the power-in section on the control board (J2) on the master board. If using transformer there is no polarity, but if using solar, positive is on top. **Do not splice the power cable wire.**

Never run 110V AC power directly to the Estate Swing. This will destroy the Estate Slide control board.

3. Before plugging in your transformer, plug the battery into the control board. The clear plastic clip gets clipped into J4 with the clip side on the left. The other side of the battery wire has a clear plastic disconnect that slides on the battery terminals. Red to Red, Black to Black. **Reversing the wires will blow the fuse.**

Never connect the power wire with the transformer plugged in. Contact between the two lead wires, even for a second, will destroy the transformer.

4. Plug the **transformer** into a 110V AC outlet.

5. *The transformer is not weather proof and must be kept in a covered area. Plug covers are available from your dealer, contact 1-800-640-GATE for a dealer in your area.*

6. The power light (P) will be on if the power and battery are connected properly. If the power light is blinking slowly then only the battery is connected, check your power connections.

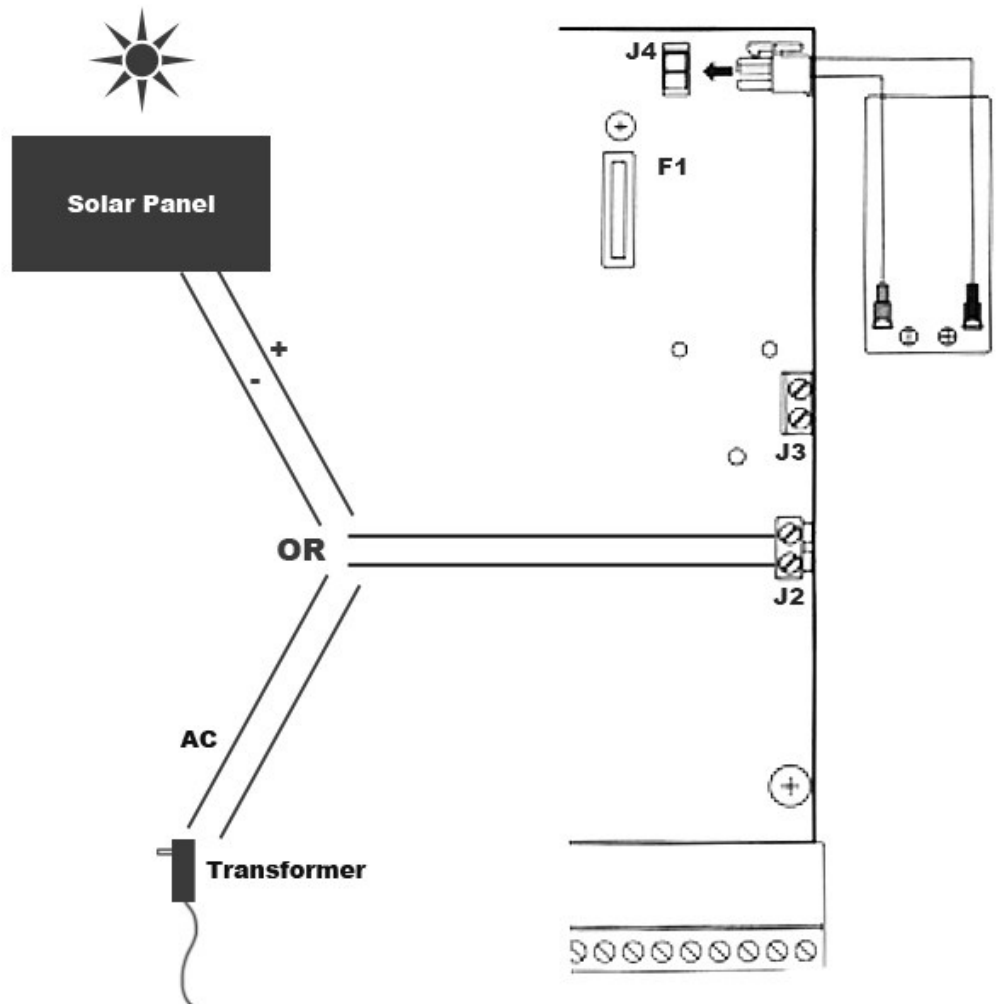

Control Board Pre-Learning Preparations

For your opener to function properly a few connections must be made prior to the learning process. Accessories should NOT be installed until after the learning process is completed.

1. Using the provided orange jumper wire, connect the normally closed safety terminals (terminal 3, 4, and 5) to one of the negative terminals (terminals 12, 13, 14, or 15). We recommend that these jumpers are later replaced with safety devices after learning is complete.

-  2. **Connect the power last.** First connect the battery to the control board and then contact the power supply to J2 on the control board.

3. **Your connections can be checked using the diagnostics mode.** Press **P2** once. One a single gate opener operation C, D, and E should be lit. After checking, press P2 again to exit diagnostics mode. To learn more about diagnostics see section 15.1.

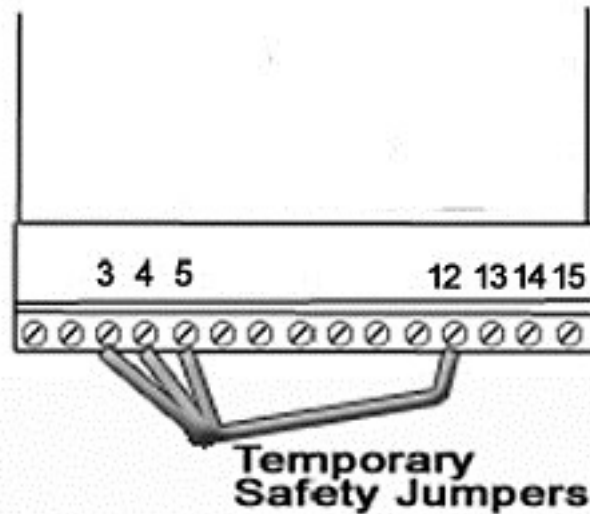

One Touch EZ Programming

NOTE: Before beginning the one touch learning procedure be sure to have the limit magnets set up. These will let your gate know where to stop during the learning process.

Enter Learning Mode

Enter the programming mode by pressing **P1** 6 times until all 5 LEDs (A,B,C,D,E) are lit. This is the learning mode.

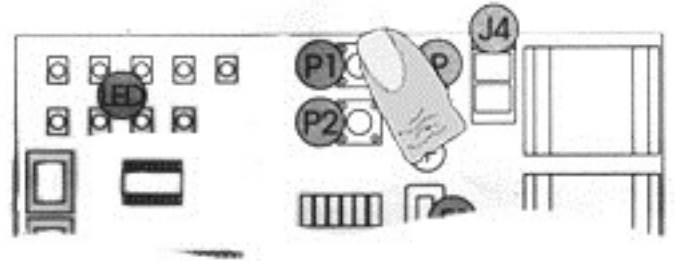

Programming

While the 5 function LEDs (A,B,C,D,E in picture) are lit steadily, briefly press (about 1 second) the **P2** button.

The operator or operators start the opening maneuver, and the function LEDs begin flashing. Wait for the operator or operators to reach the opening stops. The learning procedure has finished. **Press P1 once more to exit the learning mode before attempting to operate the opener.**

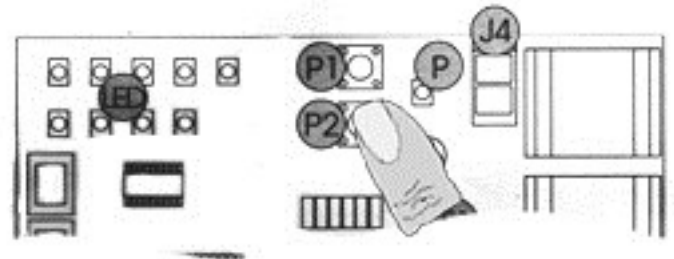

You may now test your gate opener or continue on with changes to the factory speed, force, delay settings. **To test your opener, briefly touch a wire from terminal 1 to one of the negative terminals (12, 13, 14, or 15).**

Programming Gate Movement Variables

Using the following procedures you can change factory settings such as auto close, speed, force, delays and more.

Begin the programming process by pressing **P1**. Pressing **P1** selects **A,B,C,D or E**. A, B, C, D and E correspond with the variables in the chart on the following page.

When you are on the desired variable you would like to change the setting of press **P2** to change the setting of that variable. **P2** will change the light to 1, 2, 3 or 4 which correspond with the settings on the chart below on the following page. Below is a list what each variable controls.

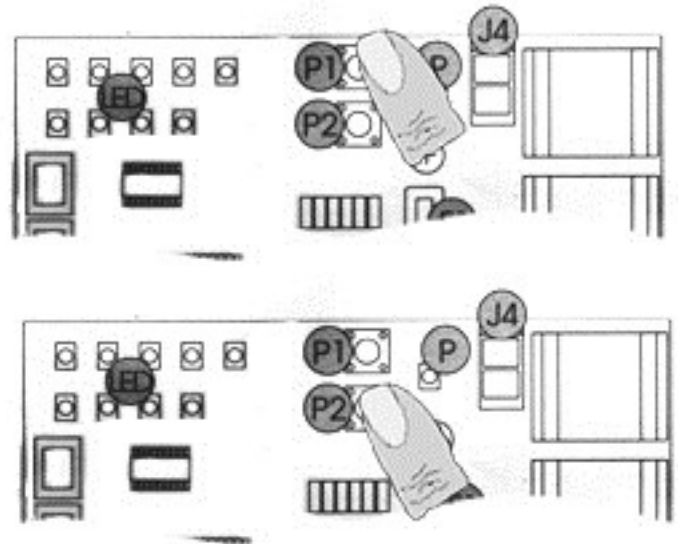

A: Switches between Function Logics. Function Logics are sets of actions that will occur when an accessory terminal connection is made or disrupted. Each set of actions is designed to give different results providing increased safety, convenience or other.

B: Switches between the amount of time the gate pauses before closing after reaching full open. By selecting Logic EP (4) all pause times will be void and the gate will remain open until an opening device is triggered.

C: Adjusts the partial opening width.

D: Switches between the amount of force the gate opener will exert before an obstruction is detected and the gate reverses directions.

E: Switches between the speed of the gate motion. This does not effect the soft start and stop.

See the following page for Gate Movement Variables LED Chart.

Gate Movement Variables LED Chart

Variable LED Definitions	
Function LED	Function
A	Function Logic — Logic flow chart found on page 13.1 and 13.2 1= A (Automatic - automatically closes the gate depending on the set pause time. It is the most common setting) 2= S (Safety - designed for higher control and accelerated levels of safety, also automatically closes the gate) 3= AP (Stepped Automatic - is very similar to automatic (A) but has a higher amount of safety. It has an increased amount of motion stop points.) 4= EP (Stepped Semi-automatic - is designed to function similar to a garage door opener. Turns off the auto close setting.)
B	Pause Times 1= 5 Seconds 2= 10 Seconds 3= 20 Seconds
C	Partial Opening Width 1= 90 cm 2= 120 cm 3= 150 cm
D	Static Force 1= Low 2= Medium Low 3= Medium High
E	Speed 1= Low 2= Medium Low 3= Medium High

Pressing P1 moves your through the Letter LEDS

After switching to the desired Letter LED, Pressing P2 moves you through the Number LEDs

Logic Summaries and Flow Charts

Logic A - Logic A (automatic) is the most common setting. It automatically closes the gate depending on the set pause time. This logic must be used in conjunction with the accessories: Free Exit Sensor and Gate Timer.

Gate Status	Result of Terminal 1 Activation	Result of Terminal 2 Activation	Result of Terminal 4 Interruption	Result of Terminal 5 Interruption
Closed	Opens leaf and re-closes after pause time		No effect	
Open and in pause before re-closing	Re-loads pause time		No effect	Re-loads pause time
Closing	Re-opens leaf		No effect	Stops motions and reverses direction after interruption
Opening	No effect		Reverses direction of motion	No effect
Stopped in mid-cycle	Closes the leaf		No effect	

Logic S - Logic S (safety) is designed for higher control and accelerated levels of safety. By triggering an opening device (i.e. push button, transmitter) the gate reverses directions preventing foreseeable accidents.

Gate Status	Result of Terminal 1 Activation	Result of Terminal 2 Activation	Result of Terminal 4 Interruption	Result of Terminal 5 Interruption
Closed	Opens leaf and re-closes after pause time		No effect	
Open and in pause before re-closing	Re-closes the leaf		No effect	Closes after 5 seconds
Closing	Re-opens the leaf		No effect	Reverses direction of motion
Opening	Re-closes the leaf		Reverses direction of motion	No effect
Stopped in mid-cycle	Closes the leaf		No effect	

Logic Summaries and Flow Charts (cont.)

Logic AP - Logic AP (stepped automatic) is very similar to automatic (A) but has a higher amount of safety. It has an increased amount of motion stop points.

Gate Status	Result of Terminal 1 Activation	Result of Terminal 2 Activation	Result of Terminal 4 Interruption	Result of Terminal 5 Interruption
Closed	Opens leaf and re-closes after pause time		No effect	
Open and in pause before re-closing	Stops operation		No effect	Re-loads pause time
Closing	Re-opens leaf		No effect	Reverses direction of motion
Opening	Stops operation		Stops motion and reverses direction after interruption	No effect
Stopped in mid-cycle	Closes the leaf		No effect	

Logic EP - Logic EP (stepped semi-automatic) is designed to function similar to a garage door opener. At full open the gate does not re-close after a pause time, it stays open until triggered to re-close. Logic EP over-rides any set pause time.

Gate Status	Result of Terminal 1 Activation	Result of Terminal 2 Activation	Result of Terminal 4 Interruption	Result of Terminal 5 Interruption
Closed	Opens leaf		No effect	
Open and in pause before re-closing	Re-closes the leaf		No effect	
Closing	Stops operation		No effect	Reverses direction of motion
Opening	Stops operation		Reverses direction of motion	No effect
Stopped in mid-cycle	Restarts motion in opposite direction the gate was previously moving before stopped in mid cycle		No effect	

Receiver Programming

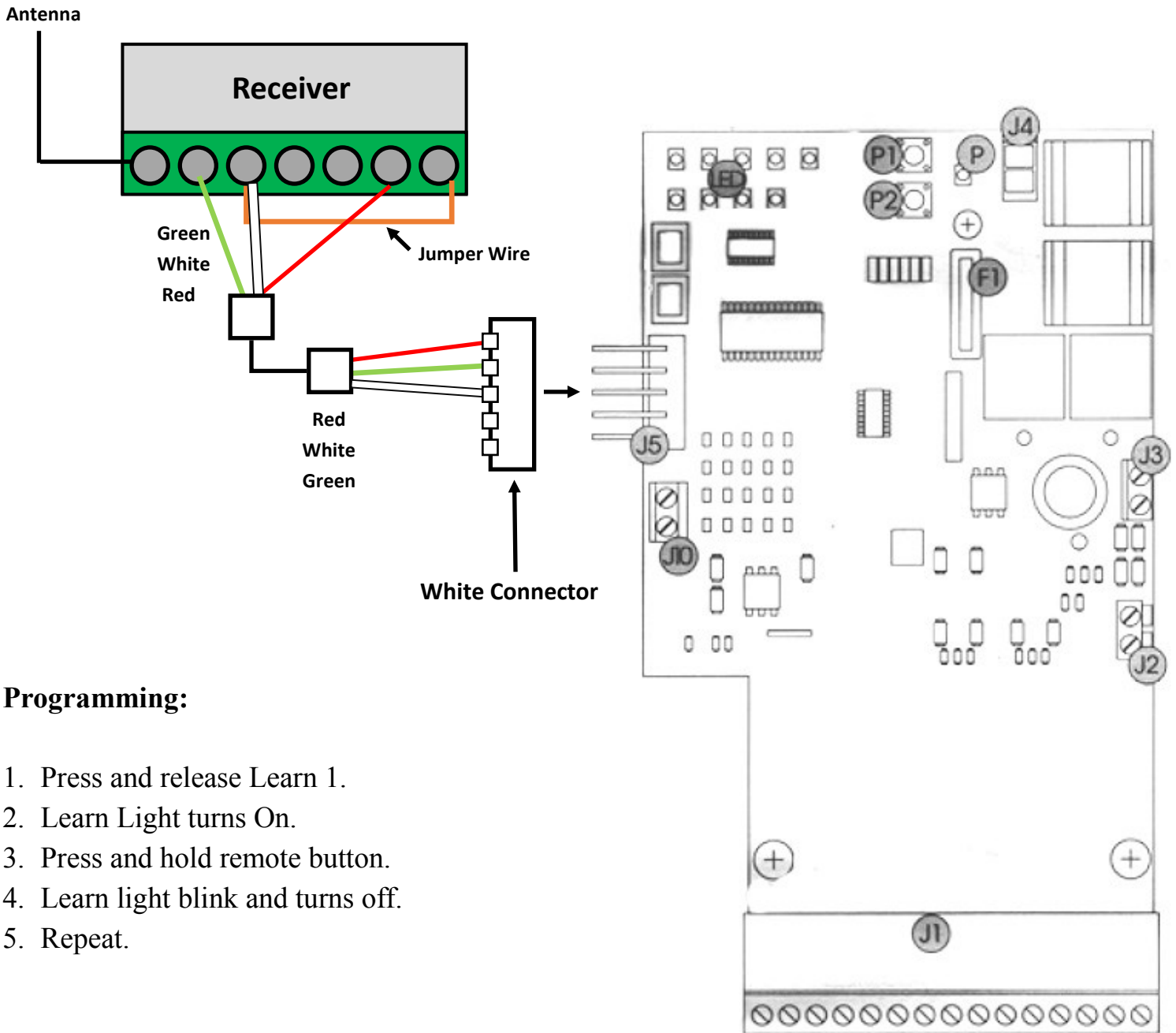

Programming:

1. Press and release Learn 1.
2. Learn Light turns On.
3. Press and hold remote button.
4. Learn light blink and turns off.
5. Repeat.

Accessory Terminals

READ prior to attempting to operate the arm. Normally Closed connections must be made for proper gate opener function. The full accessory board is only found on the master control board. The slave control board only contain one Normally Open

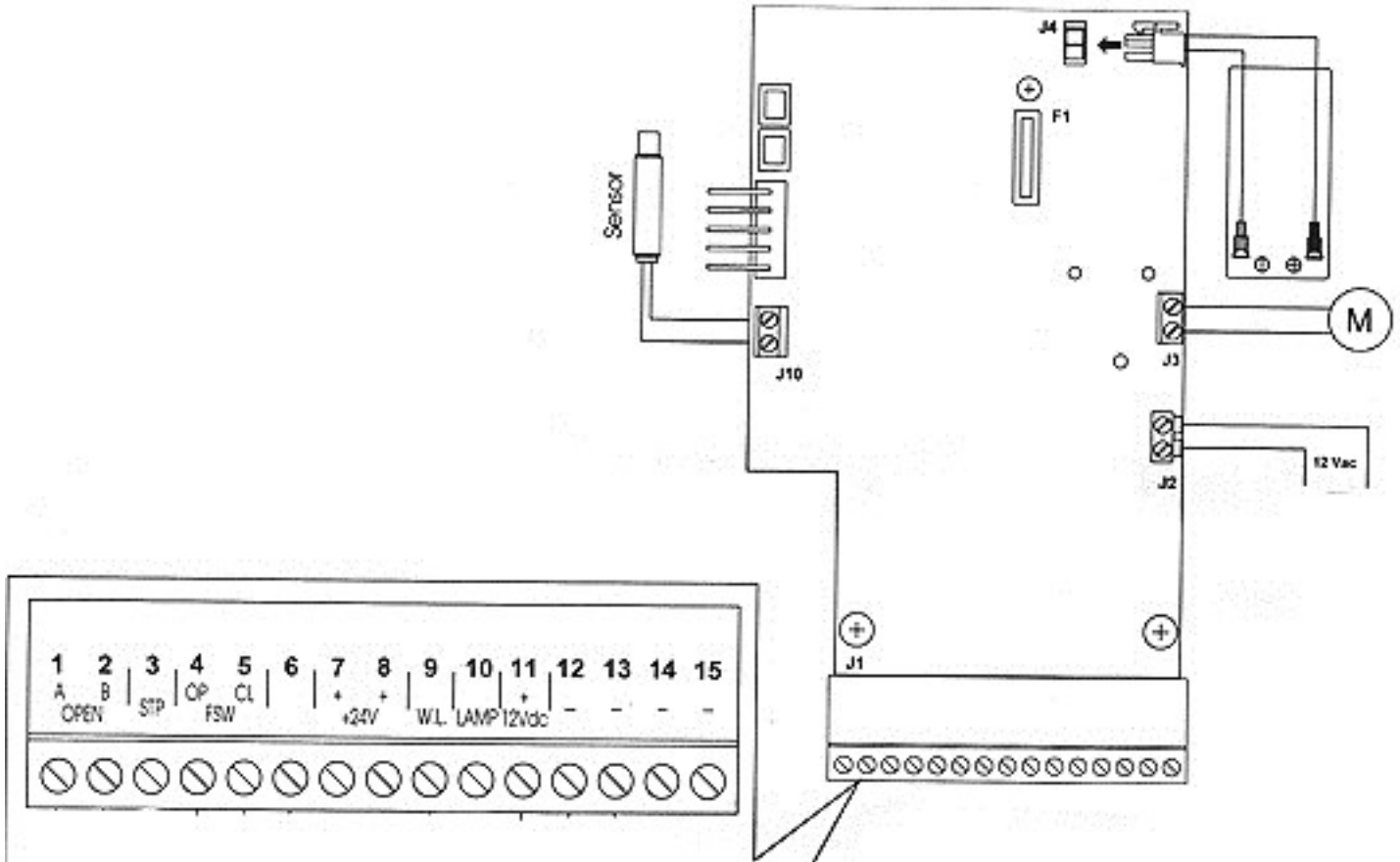

J1—Terminal Board for Master Card

Terminals

1 - “Open/Close Function” This is a normally open terminal where by any device (i.e. push button, keypad, receiver) which, by closing a contact, provides an opening and/or closing pulse for **both** gate leaves (if there is only one leaf, it will control the one leaf).

2 - “Single Leaf Open/Close Function” This is a normally open terminal where by any device (i.e. push button, keypad, receiver) which, by closing a contact, provides an opening and/or closing pulse for **only the gate leaf controlled by the master control board** (if there is only one leaf, it will control the one leaf).

3 - “Stop Command” This is a normally closed terminal where by any device (i.e. push button) which, by opening a contact, halts gate movement. **IMPORTANT:** If a connection is not made from this terminal to one of the - (negative) terminals (i.e. 12, 13, 14, 15) gate motion will not commence.

J1—Terminal Board for Master Card (cont.)

Terminals (cont.)

4 - “Opening Safety Device” This is a normally closed terminal where by any device (i.e. photocells, sensitive edge, magnetic loops) which, if there is an obstacle in the area they protect during opening, reverses gate direction to closing.

If the opening safety devices are tripped when the gate is closed, they prevent the leaf movement.

IMPORTANT: *If a connection is not made from this terminal to one of the - (negative) terminals (i.e. 12, 13, 14, 15) gate opening will not commence.*

5 - “Closing Safety Device” This is a normally closed terminal where by any device (i.e. photocells, sensitive edge, magnetic loops) which, if there is an obstacle in the area they protect during closing, reverses gate direction to opening.

If the closing safety devices are tripped when the gate is open, they prevent the leaf movement.

IMPORTANT: *If a connection is not made from this terminal to one of the—(negative) terminals (i.e. 12, 13, 14, 15) gate closing will not commence.*

6 - N/A

7, 8 - “Positive 24 Voltage” Positive 24V for powering accessories that are run by 24V DC power (i.e. locks, safety devices).

9 - “Indicator Light” When used with terminal **11**, this terminal powers and operates the indicator light. **To avoid compromising correct operation of the system, do not exceed the indicated power (12V .5Wmax).** The indicator light is lit during open, opening and blocked. The indicator is flashing during closing.

10 - “Lamp” When used with terminal **11**, this terminal powers and operates the flashing lamp output. **To avoid compromising correct operation of the system, do not exceed the indicated power (12V 21Wmax).**

11 - “Positive 12 Voltage” This is a 12V terminal used to power the indicator light, lamp and devices controlled by 12V DC.

12, 13, 14, 15 - “Negatives” Interchangeable negative terminals for use with powered accessories, safety devices and opening devices.

Simple Diagnostics

Diagnostics using the Power light on your Master Control Board.

The **P** light has a diagnostic function. There are 4 statuses.

1. Steady light indicating main power is ON and the battery is charged.
2. Flashing slowly (lights every second) indicates no main power but the battery is charged.
3. Flashing quickly (lights every 1/4 of a second) indicates main power on but discharged battery
4. Light OFF indicates no main power and discharged battery.

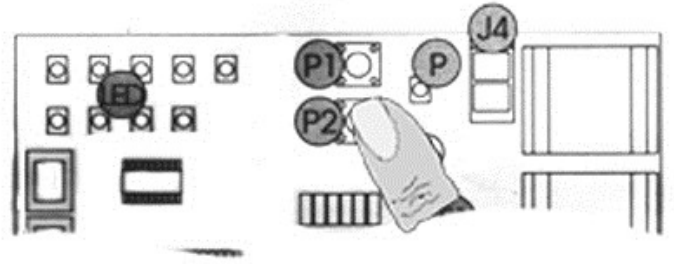

Status of accessory inputs.

The Master Control Board has the ability to verify the status of the terminal board inputs. To access this function:

When all LEDs are off (both lettered and numbered) press **P2**. The statuses of the accessory terminals in the following chart will be shown in the lettered LEDs column.

LED ON = Closed Contact

LED OFF = Open Contact

When you have finished checking, press **P2** again to exit.

If you do not , the LED status check will stay active for 5 minutes and then the board returns to all LEDs Off.

Warning: When you access the input status function, all accessories are powered, even with the gate idle. P1 is active and can be used to open and close the gate.

	Normal Operation idle LED lights	LED	ON	OFF
	A = OFF	A = Terminal 1, Open/Close Function	Opening/Closing de- vice is triggered	Opening/Closing de- vice is not triggered
	B = OFF	B = Terminal 2, Sin- gle leaf open / close	Opening/Closing de- vice is triggered	Opening/Closing de- vice is not triggered
	C = ON	C = Terminal 3, Stop Command	Motion stop device is in place and not trig- gered or jumper is in place	Motion stop device has been triggered or is not connected
	D = ON	D = Terminal 4. Opening safety device	Motion stop device is in place and not trig- gered or jumper is in place	Safety device has been triggered or is not connected
	E = ON	E = Terminal 5, Clos- ing safety device	Motion stop device is in place and not trig- gered or jumper is in place	Safety device has been triggered or is not connected
	1 = OFF if closed or open, ON if not	1 = Sensor	Sensor is not tripped	Sensor is tripped

Photocell & Safety Device Guide

Before connecting the photocells (or other devices) we advise you to select the type of operation according to the movement zone to be protected.

Opening Safety Devices: They operate only during the gate opening movement and, therefore, they are suitable for protecting the zone between the opening leaves and fixed obstacles (walls, etc.) against the risk of impact and crushing.

Closing Safety Devices: They operate only during the gate closing movement and, therefore, are suitable for protecting the closing zone against the risk of impact.

Opening/Closing Safety Devices: they operate during the gate opening and closing movements and, therefore, they are suitable for protecting the opening and closing zones against the risk of impact.

If one or more devices have the same function (opening or closing) they must be connected to each other in series. Normally Closed contacts on the accessories panel must be used.

Examples of common wiring layouts

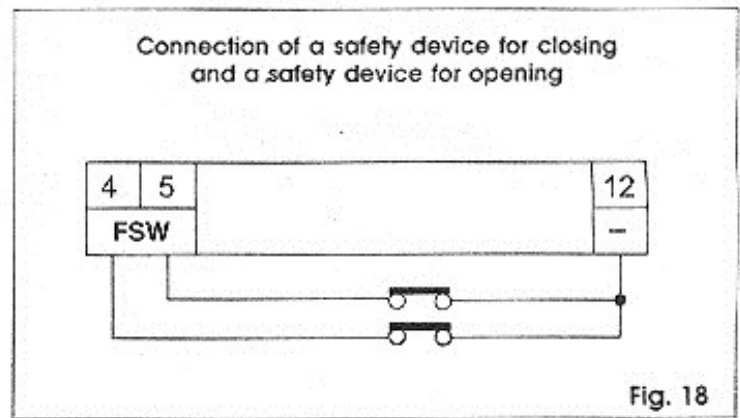
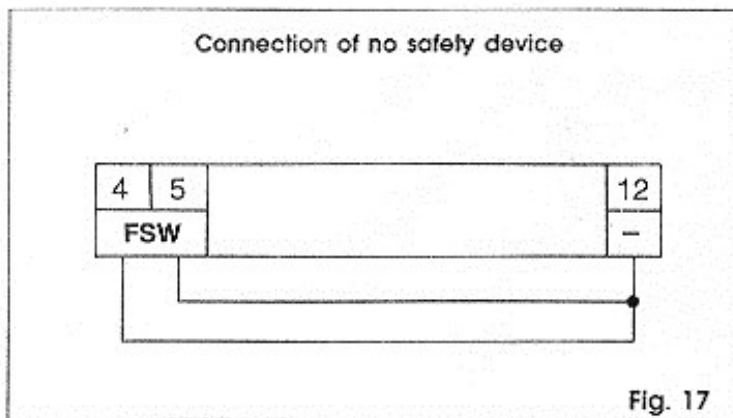

Continued on next page

Photocell & Safety Device Guide

Connection of a pair of photocells, one for opening and the other for closing.

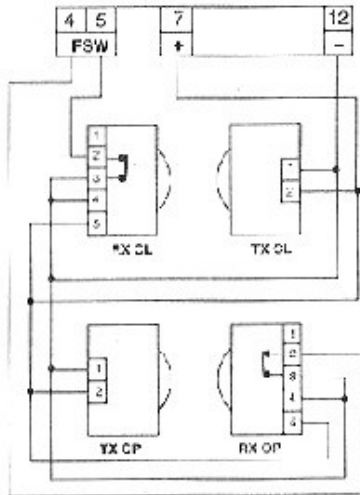

Fig. 19

Connecting of a pair of photocells, one for closing and one for opening/closing.

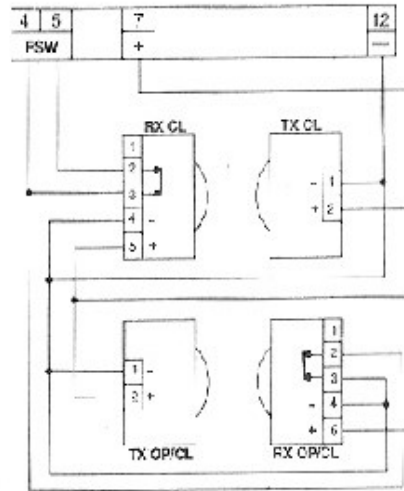

Fig. 20

Connection of 1 pair of photocells for closing.

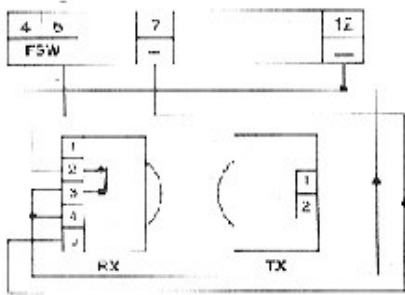

Fig. 21

Connection of 1 pair of photocells for opening.

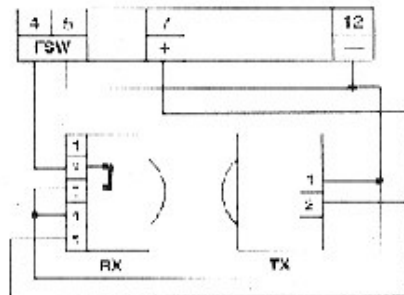

Fig. 22

Connection of 2 pairs of photocells for closing.

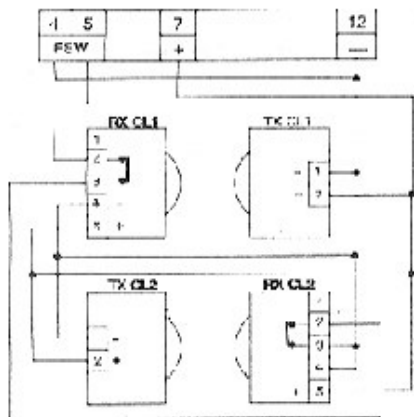

Fig. 23

Connection of a pair of closing photocells, one for opening and the other for opening/closing.

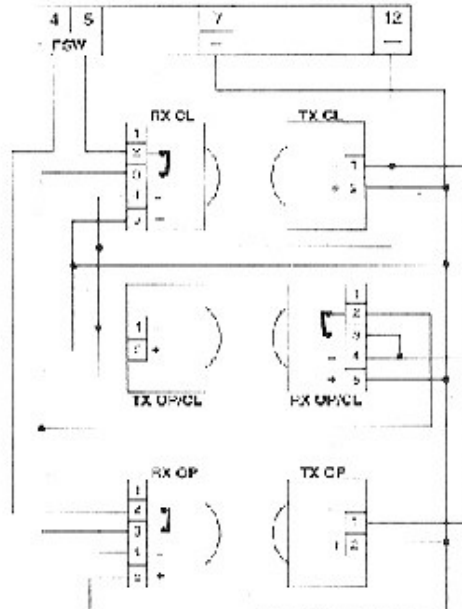

Fig. 25

Connection of 2 N.C. contacts in series (E.g. Photocells, Stop)



Fig. 24

If you call in for technical support or warranty support:
Before any control board or motor will be permitted to be
sent in for testing or warranty you will be required to
e-mail digital photos to the technician.

This is done in your best interest to save unnecessary shipping expenses and time lost. Many times we can come up with solutions to issues by seeing pictures that relay information that is impossible to relay through a phone conversation.

Below are examples of control board pictures and motor pictures that we will be looking for:

